

Bowler's Ed

Adaptive Needs

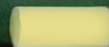

Adaptive Needs

Teaching Adapted Bowling Skills For Students With Special Needs.....	2
Poss - I - Bowling.....	3
Adapted Ball Grips.....	4
Wedge For Wheelchair Bowlers and Portable Bumpers.....	5
Ball Pushers or Bowling Sticks and Bowling Ball Holder Ring (Third Arm).....	6
Adapted Communication Methods.....	7
Bowling For The Blind or Visually Impaired.....	8-9
References and Continued Learning Resources.....	10

Teaching Adapted Bowling Skills for Students with Special Needs

The ultimate aim of teaching adapted bowling skills for students with special needs is to train students to adhere to the rules of bowling as much as possible. It is the goal of every adapted physical education teacher, classroom teacher and rehabilitation professional to make bowling a successful experience for students with special needs. Inclusion is the most important aspect of adaptive bowling because bowling is a sport that requires limited movement and a simple scoring system that is easy to administer (M. Weinman, personal communication, March 21, 2012). One way to make this experience possible is to modify the bowling exercises, bowling equipment used and the methods of communication/instructional approaches to address the special needs of these students. These adaptations will help them become successful in bowling. The following ideas are derived from a compilation of several online resources (see references at the end of this paper). These ideas are designed to facilitate the successful occupational and recreational participation of students with special needs in bowling from the perspective of occupational therapy:

Setting: Gym/multi-purpose room. Organized students accordingly.

Equipment:

1. Metal, aluminum or wooden ramp
2. One rubberized bowling ball or standard ball

Cue Words: Assisted, Unassisted, bowl or physical prompt

Instructions: Assisted (wheelchair bowlers)

1. Assisted – Have the “Guide” (APE teacher or staff) assist students by placing the ramp at the foul line. Students will make their request as to where they would like ramp by verbal or non-verbal (sign language) communication.
2. Do not place ramp beyond foul line (This will disqualify the bowler’s roll).
3. Students should adjust the ramp themselves if possible.
4. Students should roll the ball into the ramp themselves.
5. Guides should act as support for ramp as needed.
6. Guides should not look in the direction of the pins.
7. Guides should give verbal or non-verbal cue to students to bowl.



Instructions: Unassisted (ambulatory bowlers)

1. Unassisted - Students should place the ramp at the foul line.
2. Do not place ramp beyond foul line (This will disqualify the bowler’s roll)
3. Students should adjust the ramp themselves if possible
4. Students roll the ball down the ramp making sure the ram does not pass the foul line (This will disqualify the bowler’s roll).



Poss - I - Bowling

Purpose: Students learn to bowl without using a conventional three fingered bowling ball or grip

Setting: Gym/multi-purpose room. Organized students accordingly.

Equipment:

1. Pass-I-Bowl Device
2. Metal, aluminum or wooden ramp
3. One rubberized bowling ball or standard ball

Cue Words: Bowl

Instructions:

1. Guide should fasten the device to the ramp.
2. Have the "Guide" (APE teacher or staff) assist students by placing the ramp at the foul line. Students will make their request as to where they would like ramp by verbal or nonverbal (sign language) communication.
3. Do not place ramp beyond foul line (This will disqualify the bowler's roll).
4. Students should adjust the ramp themselves if possible.
5. Students should place the ball on the ramp.
6. When the students are ready to bowl, they should press the switch to release the ball.



Adapted Ball Grips

Purpose: Students learn to bowl without using a conventional three-fingered bowling ball or grip

Equipment:

1. Handle-grip bowling ball
2. Coated foam bowling ball

Cue Words: Bowl

Instructions: Handle-Grip Ball (equipped with a spring loaded handle which snaps back into the ball upon release)

1. Have the students raise the hand they bowl with by verbal or physical cues.
2. The students place their bowling hand around the handle-grip of ball to lift it.
3. Have students repeat these steps and practice holding the ball.

Instructions: Coated Foam Ball (pre-drilled for both large and small hands; weighted for easier handling and rolling)

1. Have students raise the hand they bowl with by verbal or physical cues
2. Tell them by verbal or physical cues to touch their middle two fingers and their thumb together.
3. If you have a glove available, demonstrate by putting your hand in the glove to help them visualize which fingers they will use.
4. Using a coated foam bowling ball, place your thumb and finger in the holes to demonstrate how to hold it.
5. Have students repeat these steps and practice holding the ball.

For vision impaired students give them a physical demonstration using their bowling hand.



Wedge for Wheelchair Bowlers

Purpose: Prevents students from sliding while rolling the ball

Setting: Gym/multi-purpose room

Equipment:

1. Wedge cushion

Instructions:

1. Have students or guide place wedge cushion between their non-bowling hand and the side of chair.
2. Place ball in their lap.
3. Student should wheel themselves up to the foul line, keeping their arms over the side of the chair.
4. Students should position themselves directly in front of the lane dots or arrow they wish to target.
5. Students can use pendulum swing to roll the ball away from the wheel of the chair.

In cases where the student is unable to handle the ball using the wedge technique then a ramp should be used.

Portable Bumpers

Purpose: Increase the success of the student's bowling experience and build confidence level especially for first-time or young bowlers.

Setting: Gym/multi-purpose room. Organize students accordingly.

Instructions:

1. Place the bumpers or barriers on both sides of the lanes (carpeted or non-carpeted).
2. The teacher should remove the bumpers or barriers once the students become more proficient bowlers.

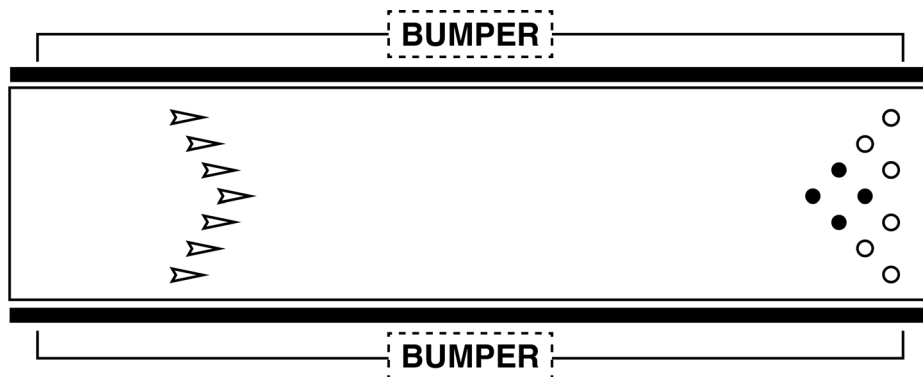

Ball Pushers or Bowling Sticks

Purpose: Increase control over the force of roll and the angle at which the bowling ball rolls down the lane (National Center on Physical Activity and Disability, 2012).

Setting: Gym/multi-purpose room. Organize students accordingly.

Equipment:

1. Bowling stick (NCPAD, 2012)
2. Adjustable Ball Pusher (NCPAD, 2012)

Instructions:

1. Have the students secure the bowling stick or adjustable ball pusher independently or with assistance from a guide.
2. Students will get positioned at the foul line, secure the ball and push the ball.
3. Students should not pass the foul line with the bowling stick or ball pusher.



Bowling Ball Holder Ring (Third Arm)

Purpose: Used as a third arm to hold the bowling ball by those who have limited or absent grip.

Setting: Gym/multi-purpose room. Organize students accordingly.

Equipment:

1. Bowling ball holder ring (Winnick, 2005)
2. Wheelchair

Instructions:

1. Have the students fasten the holder ring to the wheelchair arm.
2. Grasp a bowling ball while the bowler maneuvers down the approach line.
3. Students will get positioned at the foul line, secure the ball and push the ball into the lane.

Adapted Communication Methods

Purpose: Facilitate comprehension of bowling rules and techniques.

Setting: Gym/multi-purpose room. Organize students accordingly.

Equipment:

1. Picture cards
2. Instructions in large prints or with high contrast

Instructions:

1. Use a combination of methods that will meet the special needs of each student
2. Verbal, visual, or physical prompts
3. Modified large print/high contrast letters or pictures (for the visually-impaired)

Purpose: Facilitate comprehension of bowling rules and techniques.

Setting: Gym/multi-purpose room. Organize students accordingly.

Equipment:

1. Picture cards
2. Instructions in large prints or with high contrast

Instructions:

1. Have guides use picture cards to help students with speech delays to comprehend instructions.
2. Guide will provide instructions in large print or in high contrast to help students discriminate visual inputs.
3. Provide positive reinforcement for successful bowling.

Bowling for the Blind or Visually Impaired

Purpose: Serve as a guide to make sure bowling balls are rolled in a straight line.

Setting: Gym/multi-purpose room. Organize students accordingly.

Equipment:

1. Commercial bowling rail (NCPAD, 2012)
2. Makeshift rope (NCPAD, 2012)
3. Carpet strips (NCPAD, 2012)
4. Bells

Instructions:

1. Have students hook the elbow of their guiding arms around the rail.
2. Have students adjust the rail position so that it is straight in the middle of the foul line.
3. Put carpet strips on the sides of the carpet to guide ball positions.
4. Use bell that rings after each pin is knocked down successfully.

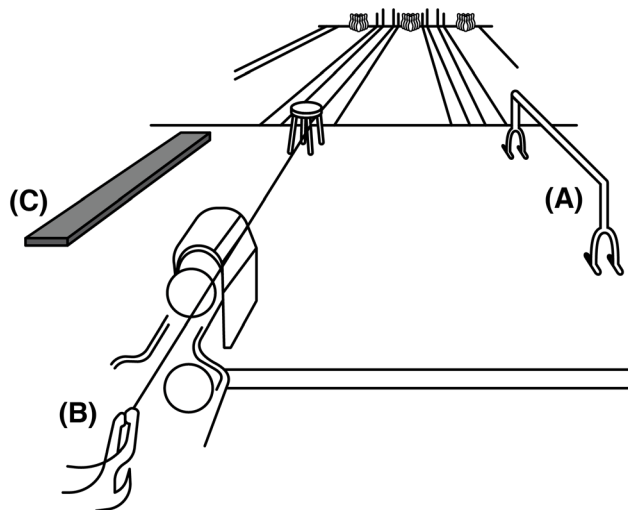

Bowling for the Deaf of Hearing Impaired

Purpose: Serve as a guide for students who are deaf and hearing impaired to aim the bowling ball successfully at the pins.

Setting: Gym/multi-purpose room. Organize students accordingly.

Equipment:

1. Flashing lights
2. Bright colored pins
3. Ball markers

Instructions:

1. Have the guides signal their turn of each student to bowl.
2. Have the guides use flashing lights to signal turns of students to bowl.
3. Have the guides position students close to them.
4. Have the guides speak slowly, clearly, and close to the students.
5. Have the guides utilize visible markers such as stars, fingernail polish, washable magic markers or even stickers to remind students of appropriate finger placements (Special Olympics, 20014).

Bowling, as a meaningful recreational activity from the perspective of occupational therapy, provides numerous benefits physically, emotionally and spiritually for people for all ages. It is an indoor activity with minimal equipment adaptations and modifications catering to the special needs of students with multiple disabilities. Consumers are urged to probe further and determine on their own which bowling equipment best fits their needs. Consultation with physicians or sports professionals may be warranted to determine the best fit. The bowling equipment suggested above does not mean to endorse any particular vendor. The adaptations and modifications to teaching bowling skills offered here are just guides and may not be applicable for everyone since students with special needs may have a wide range of physical and/or mental disabilities.

References:

Robinson, J. (2008). Adapted bowling instruction: Including students with disabilities in physical education. Manchester College. Retrieved from <http://www.manchester.edu/academics/departments/ESS/APE/documents/APEbowling.doc>

National Center on Physical Activity and Disability (NCPAD). (2012). Introduction to bowling. Retrieved from [http://www.ncpad.org/lifetime/fact sheet.php?sheet=16&view=all&print=yes](http://www.ncpad.org/lifetime/fact%20sheet.php?sheet=16&view=all&print=yes)

Reid, G., Cauchon, M., & Coolier, D. (1991). Skill acquisition by children with autism: Influence of prompts. *Adapted Physical Activity Quarterly*, 8, 357-366.

Special Olympics. (2004). Bowling coaching guide: Teaching bowling skills. Retrieved from <http://digitalguides.specialolympics.org/bowling/?#/26>

Schreibman, L. (1975). Effects of within-stimulus and extra-stimulus prompting on discrimination learning in children with autism. *Journal of Applied Behavior Analysis*, 8, 91-112.

Wing, J.K. (1976). *Early childhood autism*. London: Pergamon Press.

Winnick, J.P. (2005). *Adapted physical education and sport*. Champaign, IL (4th ed.): Human Kinetics.

Resources:

AbleData: Products. (n.d.). Retrieved from <http://www.abledata.com/abledata.cfm?pageid=19327&top=32742&trail=22,12691,32411>

Access to Recreation, Inc. (n.d.). Retrieved from <http://www.accesstr.com/AMAZING/searchresults.asp>

Bowler's Ed: In-School Bowling. (2010). Featured products. Retrieved from [http://www.metroscreenprint.net/bowlers ed school 10 1.pdf](http://www.metroscreenprint.net/bowlers%20ed%20school%2010%201.pdf)

Bowling gear: Bowling ball holder. (n.d.). Retrieved from <http://www.bowlinggearonline.info/bowling-ball-holder/>

Sportime: School Specialty. (2012). Retrieved from [http://store.schoolspecialty.com/OA HTML/ibeCCtpltmDspRte.jsp?section=&minisite=10028&item=72872](http://store.schoolspecialty.com/OA_HTML/ibeCCtpltmDspRte.jsp?section=&minisite=10028&item=72872)

O. Federico
3/29/12